

Business House Netball Association 2010

Dear BHNA Members

HIGHLIGHTS OF BHNA REMINDERS !!!

It is IMPORTANT that you read all documents contained in your 2010 package as it contains important information to guide you through a successful season. Your 2010 Package contains the following documents:

1. Letter from the President
2. Highlights of BHNA Reminders
3. 2010 BHNA Calendar of Events
4. AGM Minutes 2009
5. Council's Report
6. Disciplinary Report 2009
7. League Report 2009
8. Secretariat Report 2009
9. Miss. BHNA Committee
10. League Registration Form 2010
11. League Membership Form 2010
12. League Fees Form 2010
13. Miss BHNA 2010 Entry Form
14. Copy of Match Card (Make copies and take one to each match)

Fines are designed to ensure that members comply by submitting all documents and fees on time. Therefore avoid late fees that apply to your registration by ensuring that all your documents are completed and signed and that fees are paid by the correct dates as outlined below.

- The BHNA Affiliation Fee is due on or before the Annual General Meeting each year. This is scheduled for **Wednesday, April 28, 2010 @ 6.00 p.m.** at the PCJ Auditorium, 36 Trafalgar Road, Kgn 10.
***(The LATE fine for affiliation fees received thereafter is 50% of the affiliation fee).**
- Please indicate to the BHNA Secretariat whether your company will be fielding one or two teams in this year's competition by April 28, 2010.
- Both your League and Membership forms are due annually by May 17th. (They must be completed in full and signed by all players and officials who will be participating in the season). These must be signed by the HR or a Senior Manager within your company and the company stamp affixed in the space provided.
***A LATE fine of \$4,000 will be imposed if forms are not received by this date.**
- Your League Fees accompanied by the relevant form should be received at the BHNA Secretariat by April 28, 2010.
- ***A LATE fine of \$4,000 will be imposed for fees received after this date.**
*** Fees must be accompanied by the League Fees form.**
- To minimize match postponement requests, please submit your block-out days (.i.e. days your teams will be unable to play during the 2010 season) to the Match Secretary/BHNA Secretariat. In relation to the BHNA Open League, block-out day requests should be sent in writing before May 17, 2010, similarly, Divisional League requests should be received before July 5, 2010. N.B.,- The fees for postponed matches which are granted is \$4,500.00 and this must be paid **before your team's next scheduled match.**

- All players and team officials e.g. team coaches and managers must be holders of valid BHNA identification cards, and be prepared to present them when required. Blank ID cards are available at the Secretariat and will be issued after they are paid for. **Ensure that players sign them and the company stamp affixed. Photographs must be cut to fit the space provided and affixed with glue. Cards with loose pictures and pictures stapled on will not be accepted.**
- Ensure that information for **TWO** contact persons is clearly printed on your League and Membership forms including the following details: telephone numbers for office, cell, fax and email addresses.
- Changes in uniform design or colour along with **material samples** must be submitted for consideration prior to or at the BHNA AGM, Wednesday, April 28, 2010. **The penalty for wearing a uniform that has not been approved is \$4,000.**
- ***Be reminded that Bloomers should be the same colour as skirts and they should be cut to fit properly.**
- Ensure you abide by the correct banner dimensions as this will be included in the judging criteria of the uniform parade on June 3, 2010 @ 5:30 PM (see diagram below). **ALL TEAMS ARE REQUIRED TO PARADE.** Netball gears including uniforms, sneakers, balls etc. may be sourced through Locker Room Sports, Contact Safiya Gordon @ Locker Room Sports – Tel (876) 754- 3906, Fax (876) 754-1774.

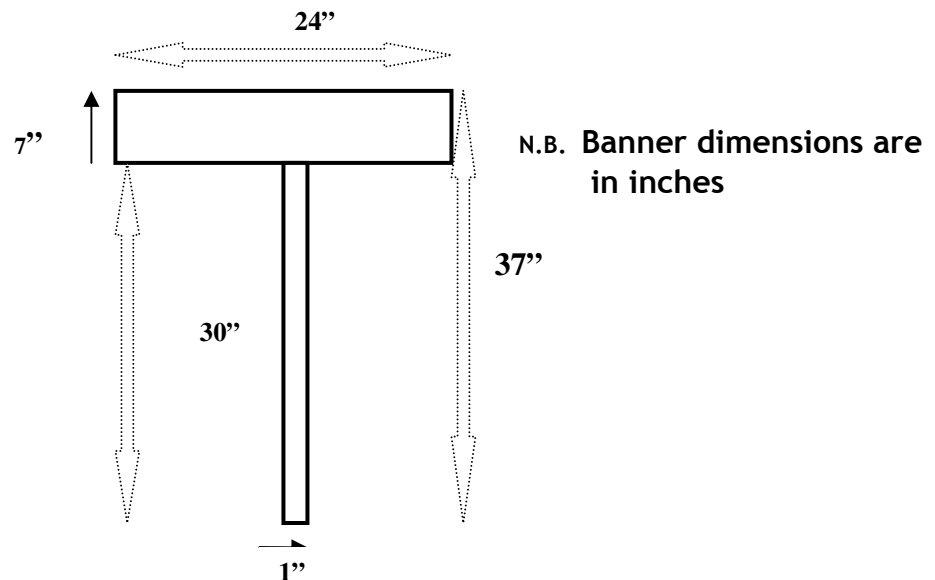

- For the 2010 season, please be reminded that coaches are restricted to having no more than two teams within the BHNA competition.
- For enquires and additional information, please call 922-3773 or e-mail @ businesshouse@cwjamaica.com .

Kindest regards,

Orinthia McCormack (Mrs)
 Administrative Assistant
 BHNA Secretariat